



2100 E. Richmond Ave
Fort Worth, TX 76104
Call: 817.926.7270
Fax: 817.926.7311
www.arch-fab.com

MODEL: ROLL FORMED

Roll Formed Aluminum Canopy

Information is subject to change. Updated 5/27/2020

Application

Architectural Fabrication, Inc. Roll Formed canopies are designed to provide the most economical approach to sun and rain protection. While this canopy is typical for truck docks, there are many customizable options to best suit your project.

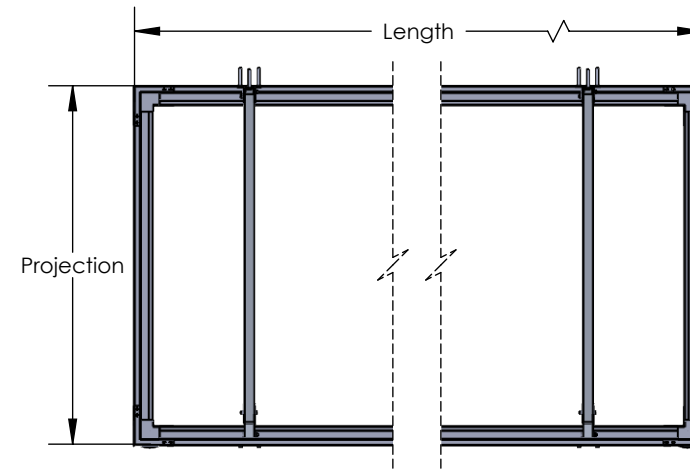
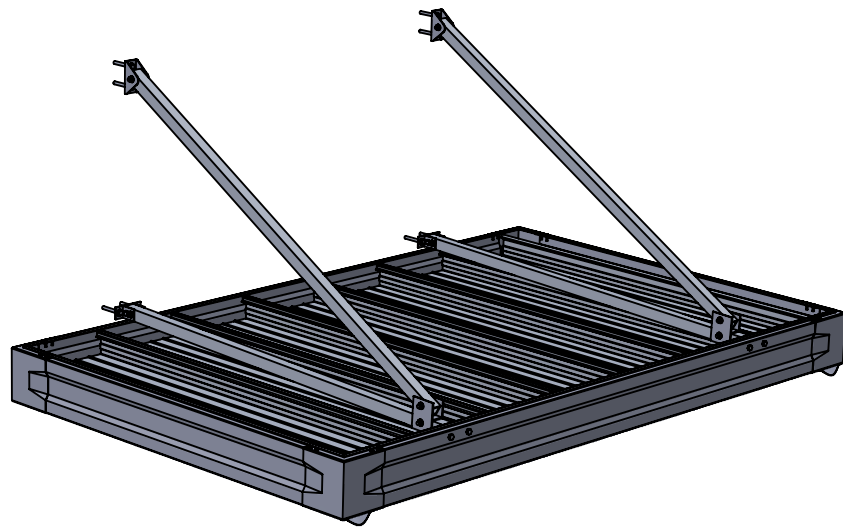

STANDARD PLAN VIEW

Deck pan removed for clarity.

FASCIA

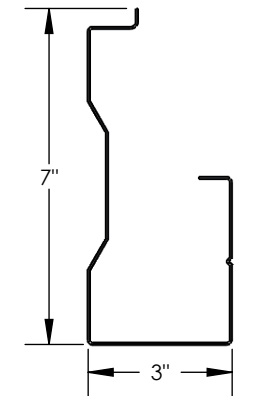

3" x 7" Gutter Fascia

INFILL

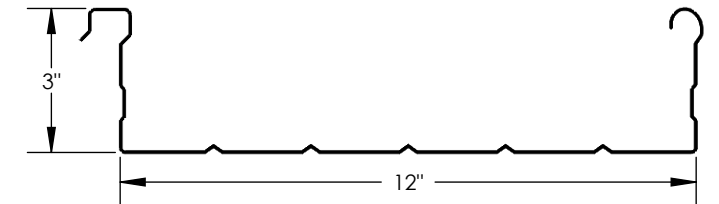

3" x 12" Deck Pan

ROLL FORMED STANDARD CONSTRUCTION

- Material: 3004-H36 Roll Formed Aluminum
- Fabrication Method: Roll Formed and Mechanically Fastened
- Infill Shape: 3" x 12" Flat Pan
- Supports: 1 1/2" Square Tube
- Fascia Profile: 3" x 7" Gutter Fascia
- Projection: 12"-120"
- Width: Unlimited
- Mounting: Concealed and above Gutter
- Scuppers: Stamped Aluminum, 2 per unit or every 24'
- Brackets: 2" x 4" Bracket, 2 fasteners

STANDARD COLORS

Colors represented in this brochure are indicative only. Actual colors may vary.

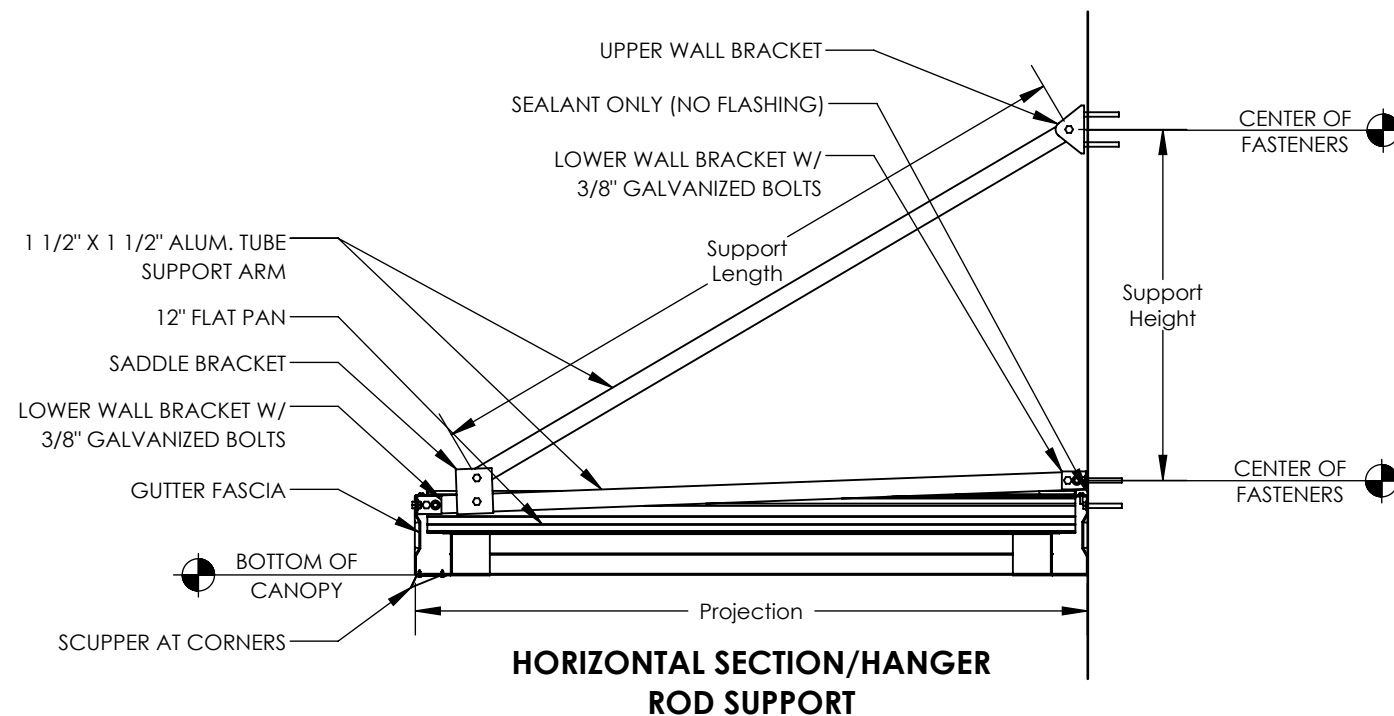

HORIZONTAL SECTION/HANGER ROD SUPPORT